

**CAPACITY TYPE LiSOCl<sub>2</sub> BATTERY  
 MODEL: ER14250**

INTERNATIONAL CODE: 1/2AA, 1/2R6, 1/2UM-5

**CHARACTERISTICS (25°C)**

- Nominal Capacity (0.5mA ~ 2V) 1.1Ah
- Nominal Potential ----- 3.6V
- Max. cont. current ----- 50mA
- Max pulse current ----- 100mA
- Weight ----- 10g
- Size ----- 4.3cm<sup>3</sup>
- Operation Temp. ----- -55+85°C

Activation Characteristics at 25°C

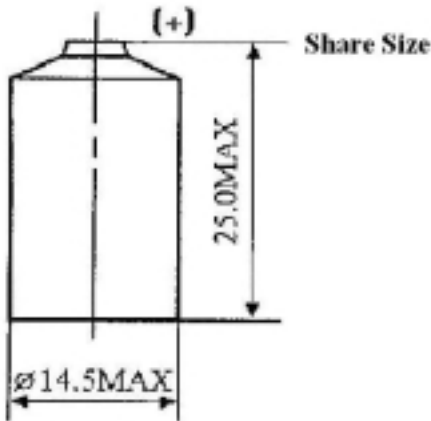
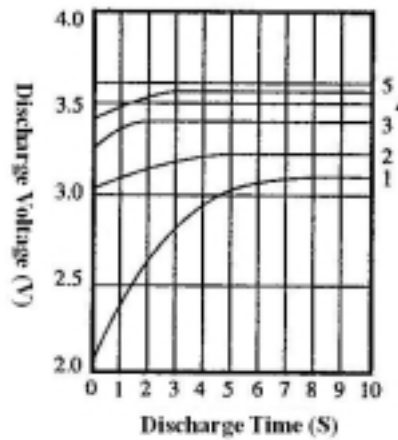

Discharge Characteristics at 25°C

